



# Lotus™

Flexshade® BY SHADEFORM

Features: Fire Rated PVC with PVDF Top Finish. Galvanised & Powder Coated Steelwork. Stainless Steel Cables & Fittings. Complete Internal Water Drainage. No Guttering Necessary, No Drip Edges. Designed to AS1170 Wind Code and to comply with other Codes worldwide for 160km/hr (45m/sec) wind speed.

## LOTUS™ SERIES

### HEXAGONAL MODULE LOTUS™ 14, 19, 25

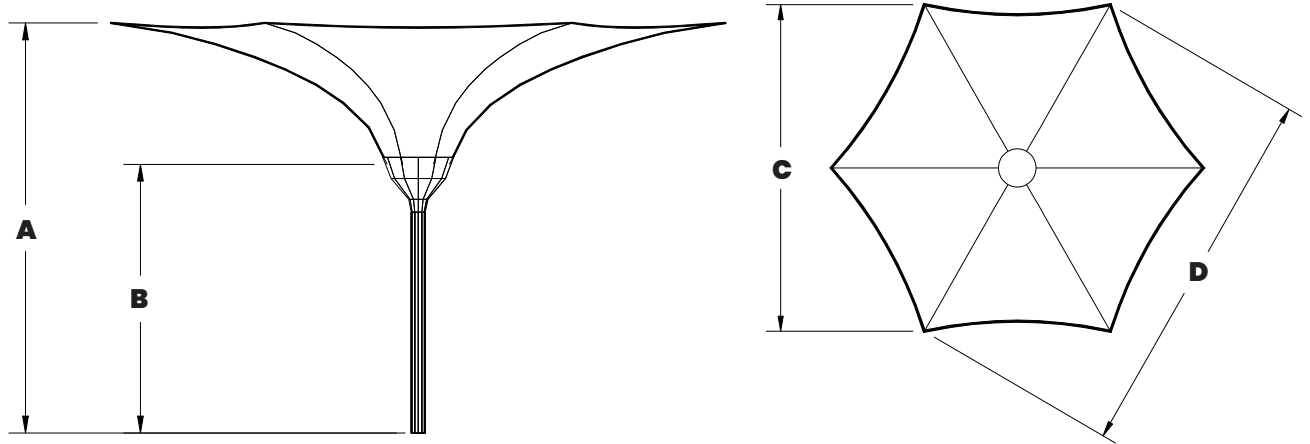

TYPE	*A	*B	*C	*D	SHIPPING	
					DIMENSIONS	WEIGHT
Lotus *16	2880	1900	3695	4270	3100 x 420 x 420 mm	165 kg
Lotus *19	3330	2000	5015	5790	3550 x 750 x 750 mm	350 kg
Lotus *25	3750	2000	6600	7620	4500 x 750 x 750 mm	700 kg

Lotus™ Cluster Flexshade Lotus™ modules can be connected to provide weatherproof cover.

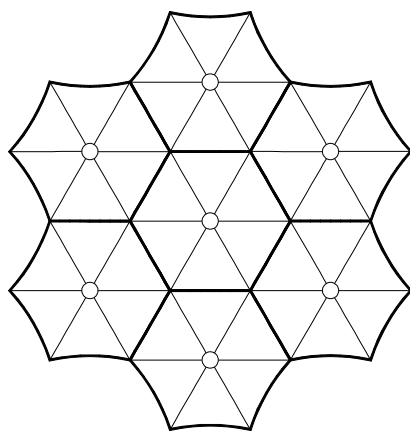

Flexshade® Lotus™ can be designed to suit specific customer requirement for height and plan dimension.

**LOTUS - L\*14, L\*19, L\*25**

Wind Rating : 160km/hr (45m/sec)  
Exposure B to ASCE 7-98

Plan Areas : L\*14 - 11 sq.m (118 sq.ft)  
L\*19 - 19 sq.m (204 sq.ft)  
L\*25 - 32 sq.m (344 sq.ft)

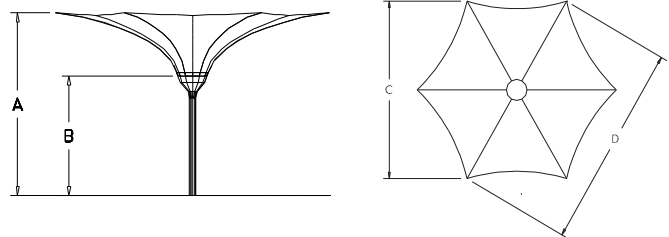

TYPE	A	B	C	D
L*14	2280 mm 9'6"	1900 mm 6'3"	3695 mm 12'4"	4270 mm 14'3"
L*19	3330 mm 11'6"	2000 mm 6'7"	5015 mm 16'6"	5790 mm 19'
L*25	3750 mm 12'3"	2000 mm 6'7"	6600 mm 21'7"	7620 mm 25'

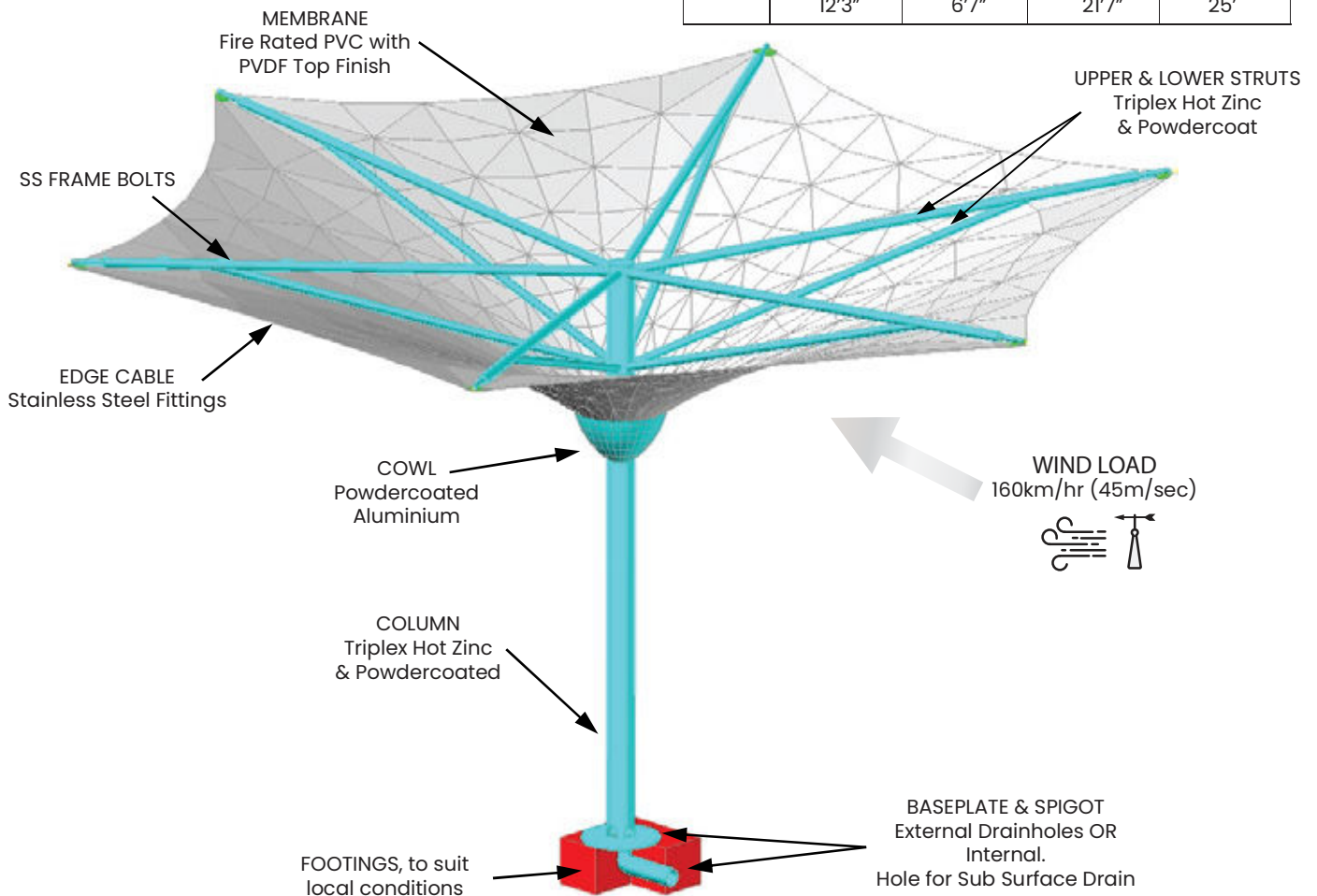

Flexshade® Lotus™ can be designed to suit specific customer requirement for height and plan dimension.